

DIBOND'S DISTINCT ADVANTAGES MAKE SPECIFYING EASY

PROVEN QUALITY

- DIBOND® is produced in Germany by the makers of ALUCOBOND®, the original and the world's most widely recognized aluminium composite panel.
- Manufactured by one of the world's largest and longest established aluminium producers Alcan Singen GmbH using corrosion resistant A5005 alloy.
- DIBOND® has a factory applied coil coated modified polyester paint finish; recognized and proven worldwide as the best coating system for signage and interiors.
- DIBOND® is very cost effective, even in the most complex situations.
- Numerous prestigious projects have been carried out in Australia using DIBOND® since the early 1990's.

COLOURS/FINISHES

- Available in over 50 colours/finishes including: Standard colours, High gloss, Matt, Gloss metallic, Butlerfinish, Eloxal (anodized), Complimentary colours and DIBOND® Décor timber look finishes.

WIDE RANGE OF SIZES

- DIBOND® is available in a wide range of sheet sizes and thicknesses.

FEATURES & APPLICATIONS

- DIBOND® is lightweight, extremely flat and rigid.
- DIBOND® has excellent vibration dampening characteristics.
- DIBOND® can be bent, curved or shaped to any angle.
- DIBOND® can be used for signage, display, interior fitouts, soffit linings, furniture, internal wall and ceiling cladding.
- DIBOND® is fully recyclable.

PROMPT DELIVERY

- Substantial stocks of DIBOND® are kept at our warehouses in Sydney, Brisbane, Melbourne, Adelaide, Perth and Auckland.

TECHNICAL SUPPORT

- Free technical support and backup available.

AUSTRALIA'S MOST POPULAR COMPOSITE PANEL

Distributed by:



ALUCOBOND ARCHITECTURAL
A Division of Halifax Vogel Group Pty Ltd
T VICTORIA: (03) 9319 3700
T NEW SOUTH WALES: (02) 8525 6900
T QUEENSLAND: (07) 3718 2360
T WESTERN AUSTRALIA: 1300 700 917
T SOUTH AUSTRALIA: (08) 8348 6800
E info@alucobond.com.au
W www.alucobond.com.au



Decorative Building Products

HALIFAX VOGEL GROUP PTY LTD
Australia:
T 1300 854 166
F 1300 658 889
New Zealand:
T +64 (0)9 580 1093
F +64 (0)9 580 0493
E building@hvg.net.au
W www.hvgbuilding.com.au

EXAMPLES OF SOME TYPICAL DIBOND® EXTERIOR TYPE FIXING DETAILS

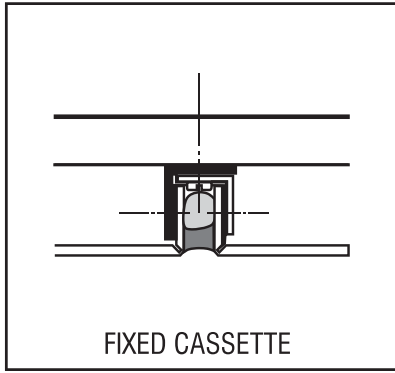

FIXED CASSETTE

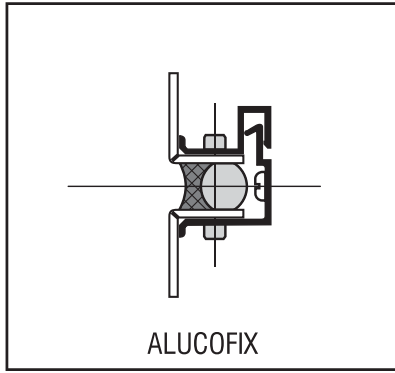

ALUCOFIX

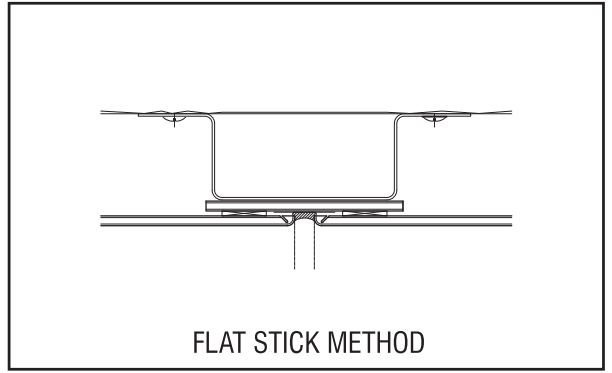

FLAT STICK METHOD

EXAMPLES OF SOME TYPICAL DIBOND® INTERIOR TYPE FIXING DETAILS

Extrusions suitable for 3mm DIBOND® only.

INTERNAL CORNER DETAILS All samples shown with (but not limited to) gyprock on stud framing

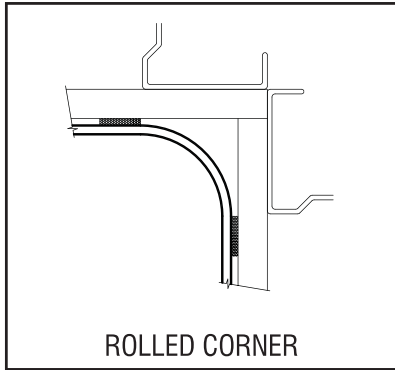

ROLLED CORNER

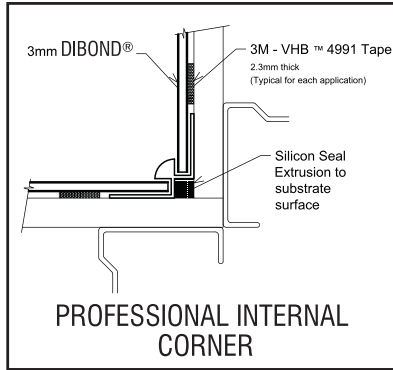

PROFESSIONAL INTERNAL CORNER

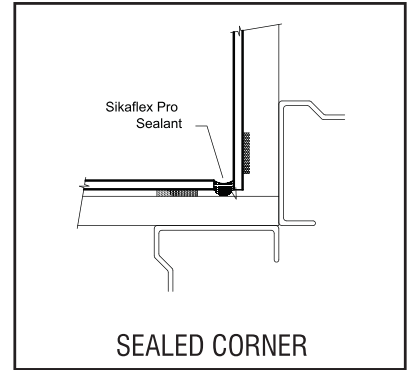

SEALED CORNER

EXTERNAL CORNER DETAILS All samples shown with (but not limited to) gyprock on stud framing

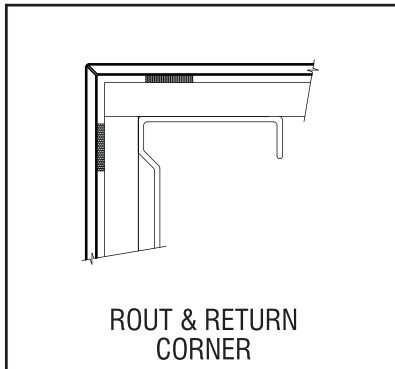

ROUT & RETURN CORNER

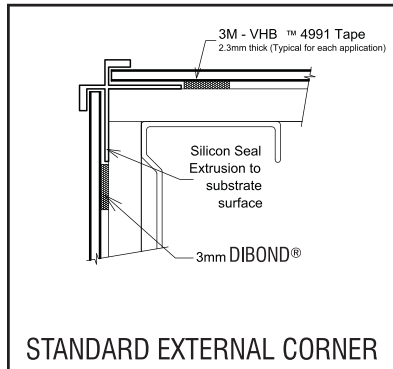

STANDARD EXTERNAL CORNER

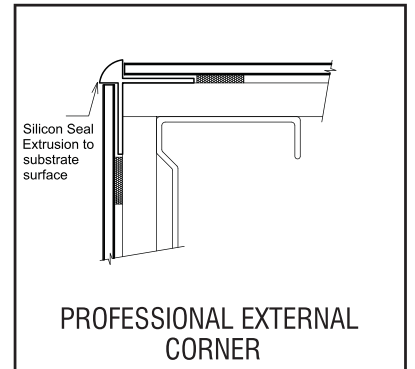

PROFESSIONAL EXTERNAL CORNER

JOINT DETAILS All samples shown with (but not limited to) rendered finish

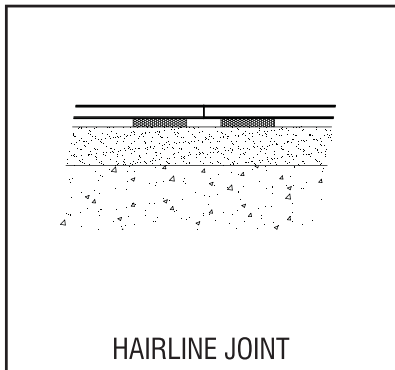

HAIRLINE JOINT

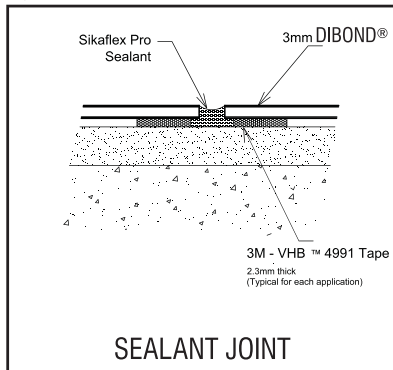

SEALANT JOINT

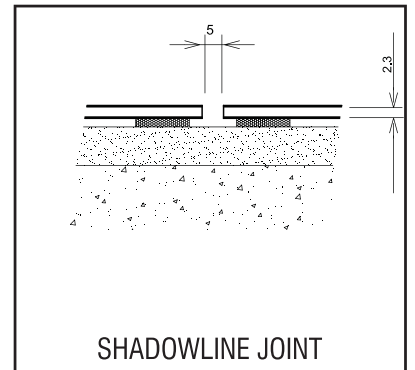

SHADOWLINE JOINT

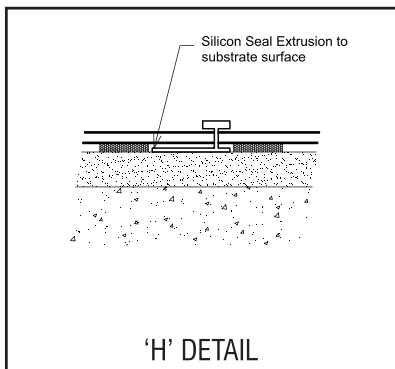

'H' DETAIL

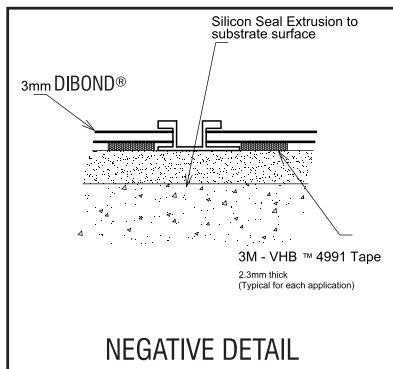

NEGATIVE DETAIL

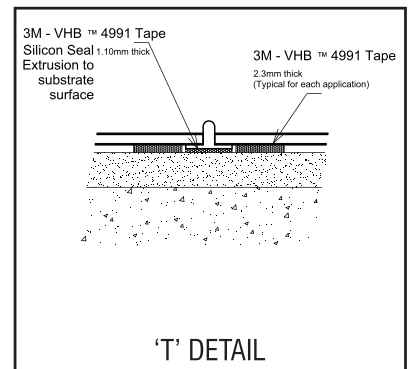

'T' DETAIL