

PROPOSED SPECIFICATION FOR PVF2 ALUCOBOND® Aluminium Composite Panel Cladding System Water tight cassette panel system - 4mm thick

1. SCOPE OF WORK

The scope of work includes the design, supply fabrication and installation of ALUCOBOND® aluminium composite panel cladding, complete with all necessary sub-structures, anchors, hardware and fittings to provide a total installation, fully in conformity with the requirements and intent of the drawings and specification herein.

The cladding system shall be installed complete with matching copings, flashings etc. by an approved cladding specialist subcontractor in accordance with the manufacturer's recommendations.

2. DESIGN CONCEPT

The proposed ALUCOBOND® cladding shall be based on a watertight cassette panel system and divided into individual panels as indicated on architectural drawings.

A typical panel shall be fitted with extruded aluminium angle brackets. Such brackets shall be positioned in such a manner that brackets attached to adjacent panels shall overlap.

Fastening of panels shall take place and be concealed within the panel joints through the overlapping angle brackets into furring channels behind.

A construction joint of 10mm minimum shall be provided between cladding elements to cater for easy panel installation. All fixing and joint details shall be designed to provide for the expected thermal and structural movements.

To conceal fixings and form a watertight seal, seal construction joint with a suitable silicone or polyurethane sealant over a closed cell foam backing rod. Sealant applied to be of a type in accordance with sealant manufacturer's recommendations.

Horizontal cladding areas ideally should have a slope of 1:15 (4° approx) and to prevent staining should slope away from visible vertical facade areas.

MELBOURNE

25 West Park Drive
Derrimut VIC 3030 Australia
T (03) 9394 3130 F (03) 9394 3129

SYDNEY

29 Henderson Street
Turrella NSW 2205 Australia
T (02) 8525 6900 F (02) 9556 6068

BRISBANE

128 - 132 Mica Street
Carole Park QLD 4300 Australia
T (07) 3718 2360 F (07) 3718 2399

WESTERN AUSTRALIA

72 Bushland Ridge
Bibra Lake WA 6163 Australia
T (08) 9494 0100 F (08) 9494 0190

PROPOSED SPECIFICATION FOR PVF2 ALUCOBOND® Aluminium Composite Panel Cladding System Water tight cassette panel system - 4mm thick

3. DESIGN CRITERIA

All ALUCOBOND® composite panel cladding shall be so designed to meet or exceed specified performances required for the prevailing local weather conditions.

3.1. Design Wind Loading : _____ N/m² positive and negative
No cladding element shall sustain permanent deformation or failure under loading equivalent 1.5 times the design wind pressure specified.

3.2. Deflection: Deflection of any aluminium frame shall not exceed 1/150 of the clear span.

3.3. Expansion and Contraction

The cladding shall be so fabricated and erected as to provide for all expansion and contraction of the components. Any temperature change due to climatic conditions shall not cause harmful buckling, opening of joints, undue stress on fastening and anchors, noise of any kind or other defects.

3.4. Flatness

With a gloss of 30% according to GARDNER Scale, the cladding surface taken individually shall not have any irregularities such as oil canning, waves, buckles and other imperfections when viewed at any position but not less than at an angle of 15 degrees to the true plane of the panel, with natural lighting of incident of not less than the same angle.

MELBOURNE

25 West Park Drive
Derrimut VIC 3030 Australia
T (03) 9394 3130 F (03) 9394 3129

SYDNEY

29 Henderson Street
Turrella NSW 2205 Australia
T (02) 8525 6900 F (02) 9556 6068

BRISBANE

128 - 132 Mica Street
Carole Park QLD 4300 Australia
T (07) 3718 2360 F (07) 3718 2399

WESTERN AUSTRALIA

72 Bushland Ridge
Bibra Lake WA 6163 Australia
T (08) 9494 0100 F (08) 9494 0190

**PROPOSED SPECIFICATION FOR PVF2 ALUCOBOND®
Aluminium Composite Panel Cladding System
Water tight cassette panel system - 4mm thick**

4. MATERIAL AND FINISHES

4.1. ALUCOBOND®

All cladding shall be 4.0mm thick ALUCOBOND® aluminium composite panel comprising a polyethylene core sandwiched between two skins of aluminium alloy PERALUMAN-100 (AIMg1-NS41)

- (a) Aluminium skin: 0.5mm thick
- (b) Mechanical Properties: : Tensile strength ≥ 130 N/mm²
0.2% proof stress ≥ 90 N/mm²
Elongation 5.65 $\sqrt{So} \geq 10\%$
Modulus of Elasticity 70,000 N/mm²
- (c) Vibration: Average airborne – sound transmission loss
and Noise Damping R - 5 dB (DIN 4109)
- (d) Rigidity (E x I) : 0.240 kNm²/m
- (e) Panel weight : 5.5kg/m²
- (f) Finish

The external cladding panel surface shall be factory prefinished by the manufacturer with a PVF2 (Fluorocarbon) coating applied through a "REVERSE ROLLER COATING" process. Total dry-film thickness of the coating shall be 25 microns minimum consisting of a chromate conversion coating, an inhibitive primer and a top coat. The coated surface shall comply strictly with the "Specification for coated coil for exterior building applications" issued by ECCA (European Coil Coating Association) to achieve The Quality Label Category 1. The finished surface shall be factory protected with a self-adhesive peel-off foil, tested to withstand at least 6 months exposure to local weather conditions without losing the original peel-off characteristic or causing stains or other damages.

Application of the PVF2 coating system by means of spray coating after forming and shaping of the cladding elements shall not be permitted.

The reverse side of the cladding panel surface facing the wall shall be in mill finish.

MELBOURNE	SYDNEY	BRISBANE	WESTERN AUSTRALIA
25 West Park Drive	29 Henderson Street	128 - 132 Mica Street	72 Bushland Ridge
Derrimut VIC 3030 Australia	Turrella NSW 2205 Australia	Carole Park QLD 4300 Australia	Bibra Lake WA 6163 Australia
T (03) 9394 3130 F (03) 9394 3129	T (02) 8525 6900 F (02) 9556 6068	T (07) 3718 2360 F (07) 3718 2399	T (08) 9494 0100 F (08) 9494 0190

**PROPOSED SPECIFICATION FOR PVF2 ALUCOBOND®
Aluminium Composite Panel Cladding System
Water tight cassette panel system - 4mm thick**

(g) Colour/Gloss : As per ALUCOBOND® standard colour chart with approx. 30% gloss according to GARDNER scale

4.2. Aluminium extrusions

Non visible extrusion shall be of aluminium alloy AA 6063-T5 in mill finish.

4.3. Fixings

- (a) Fasteners, including concealed screws, nuts, bolts and other items required for connecting aluminium to aluminium or aluminium to steel shall be of non-magnetic stainless steel.
- (b) Blind rivets used for fastening ALUCOBOND® panel to aluminium sub-frame shall be of aluminium alloy with stainless steel mandrel.
- (c) All fixing anchors, brackets and similar attachments used in the erections, shall be of aluminium, non-magnetic stainless steel, zinc coated steel, or hot dip zinc galvanised steel.

4.4. Dissimilar Materials

Where two surfaces of dissimilar material come into contact, such surfaces shall be insulated with a layer of PVC or Polyethylene tape.

5. FABRICATION

5.1. All cladding panels shall be factory fabricated and assembled in compliance with the manufacturer's Data Sheets and to the best standard of workmanship under experienced factory supervision and control.

MELBOURNE	SYDNEY	BRISBANE	WESTERN AUSTRALIA
25 West Park Drive Derrimut VIC 3030 Australia T (03) 9394 3130 F (03) 9394 3129	29 Henderson Street Turrella NSW 2205 Australia T (02) 8525 6900 F (02) 9556 6068	128 - 132 Mica Street Carole Park QLD 4300 Australia T (07) 3718 2360 F (07) 3718 2399	72 Bushland Ridge Bibra Lake WA 6163 Australia T (08) 9494 0100 F (08) 9494 0190

PROPOSED SPECIFICATION FOR PVF2 ALUCOBOND® Aluminium Composite Panel Cladding System Water tight cassette panel system - 4mm thick

- 5.2. All panels shall be cut and routed using equipment and tools recommended and approved by the panel manufacturer. After folding into cassettes, an extruded aluminium profile shall be fixed to the minimum 25mm deep return bend using \varnothing 5mm blind rivets.

Rivets shall be properly positioned not less than 15mm from the edge of the ALUCOBOND® panel and the distance between rivets shall not exceed 500mm.

The corners of the panels shall be as per manufacturer's drawing No. 6.6.12.

- 5.3. If reinforcement of the panel will be required, an extruded aluminium profile of suitable cross-section and strength shall be bonded to the reverse side of the ALUCOBOND® panel using double sided adhesive tape "3M VHB4991" or PU adhesive "Sikaflex-221". Application of bonding systems shall be in strict conformity with the manufacturer's specification and recommendations. The ends of the stiffener shall be mechanically joined to the panel sub-frame.

- 5.4. Each panel shall be marked on the reverse side for easy identification of size and location.

- 5.5. Finished panels shall be stored and transported to site in vertical position, face-to-face resp. back-to-back, with adequate protection to prevent scratches and dents.

- 5.6 The factory applied protective peel-off foil shall only be removed after the panels have been installed on site.

6. INSTALLATION

- 6.1 Panels shall be stored on site in vertical position, face-to face resp. back-to back-, with adequate protection to prevent scratches and dents.

- 6.2 Any component parts which are observed to be defective in any way, including warped, bowed, dented, abraded and broken members must not be installed. Member or parts which have been damaged during installation or thereafter before the time of final acceptance shall be removed and replaced.

MELBOURNE

25 West Park Drive
Derrimut VIC 3030 Australia
T (03) 9394 3130 F (03) 9394 3129

SYDNEY

29 Henderson Street
Turrella NSW 2205 Australia
T (02) 8525 6900 F (02) 9556 6068

BRISBANE

128 - 132 Mica Street
Carole Park QLD 4300 Australia
T (07) 3718 2360 F (07) 3718 2399

WESTERN AUSTRALIA

72 Bushland Ridge
Bibra Lake WA 6163 Australia
T (08) 9494 0100 F (08) 9494 0190

PROPOSED SPECIFICATION FOR PVF2 ALUCOBOND® Aluminium Composite Panel Cladding System Water tight cassette panel system - 4mm thick

- 6.3 No cutting, trimming, welding or brazing of any component parts during erection, in any manner which would damage the finish, decrease the strength or result in a visual imperfection or failure in performance shall be executed during erection. Component parts which require alteration shall be returned to shop for fabrication, if necessary replaced with new parts.
- 6.4 Anchorage of the cladding structure to the building structure shall be by approved methods in strict accordance to the specification and approved shop and/or erection drawing. Supporting brackets shall be so designed as to provide three-dimensional adjustments and accurate location of cladding components.
- 6.5 All component parts shall be installed level, true to line with uniform joints and reveals.
- Maximum deviation for vertical member: 3mm max. in a 5.200m run and 5mm max. in an 11.00m run.
- Maximum deviation for horizontal members: 3mm max. in an 8.500m run.
- Maximum offset from true alignment between the abutting members shall not exceed 1.0mm.
- The tolerance of the width of the joints between two panels shall be maximum ± 2 mm.
- 6.6 Cladding panels shall be left protected by the factory applied peel-off foil as long as possible. Under no circumstances shall the peel-off foil on individual panels be partially removed and left exposed to weathering.
- 6.7 Before handing over of the completed cladding, all peel-off foil shall be removed. Panels which were exposed to weathering without peel-off foil shall be cleaned in accordance with manufacturer's recommendation.

MELBOURNE

25 West Park Drive
Derrimut VIC 3030 Australia
T (03) 9394 3130 F (03) 9394 3129

SYDNEY

29 Henderson Street
Turrella NSW 2205 Australia
T (02) 8525 6900 F (02) 9556 6068

BRISBANE

128 - 132 Mica Street
Carole Park QLD 4300 Australia
T (07) 3718 2360 F (07) 3718 2399

WESTERN AUSTRALIA

72 Bushland Ridge
Bibra Lake WA 6163 Australia
T (08) 9494 0100 F (08) 9494 0190

PROPOSED SPECIFICATION FOR PVF2 ALUCOBOND®
Aluminium Composite Panel Cladding System
Water tight cassette panel system - 4mm thick

DETAIL OF CUT-OUT
TO CORNER

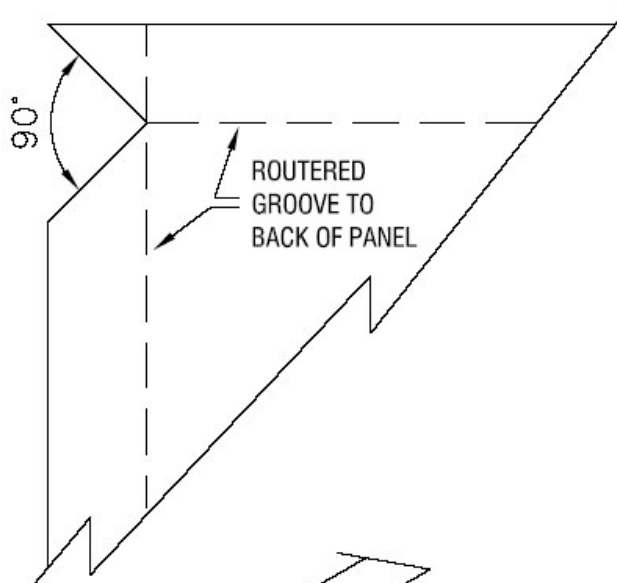

DETAIL OF
FOLDED
CORNER

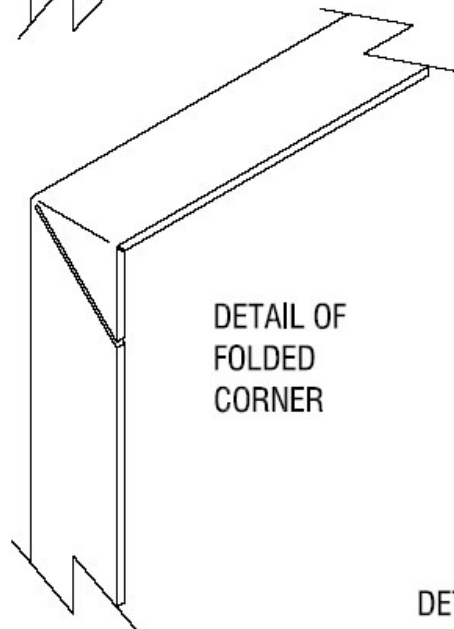

DETAIL SHEET 6.6.10

MELBOURNE

25 West Park Drive
Derrimut VIC 3030 Australia
T (03) 9394 3130 F (03) 9394 3129

SYDNEY

29 Henderson Street
Turrella NSW 2205 Australia
T (02) 8525 6900 F (02) 9556 6068

BRISBANE

128 - 132 Mica Street
Carole Park QLD 4300 Australia
T (07) 3718 2360 F (07) 3718 2399

WESTERN AUSTRALIA

72 Bushland Ridge
Bibra Lake WA 6163 Australia
T (08) 9494 0100 F (08) 9494 0190