

# ALUCOBOND®

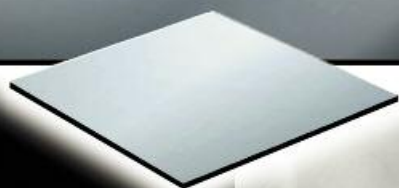

Processing

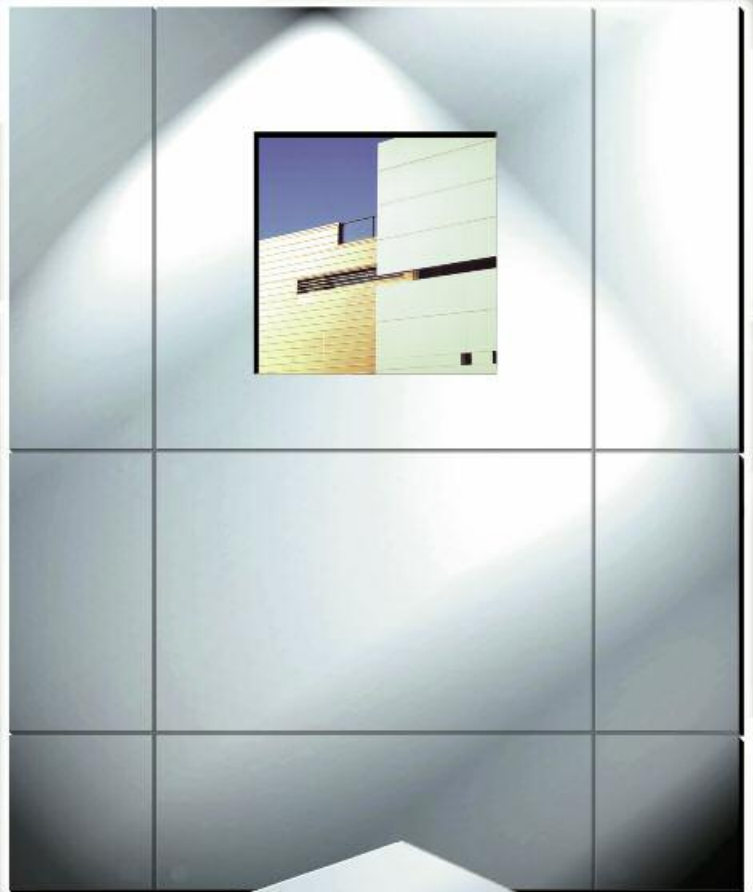
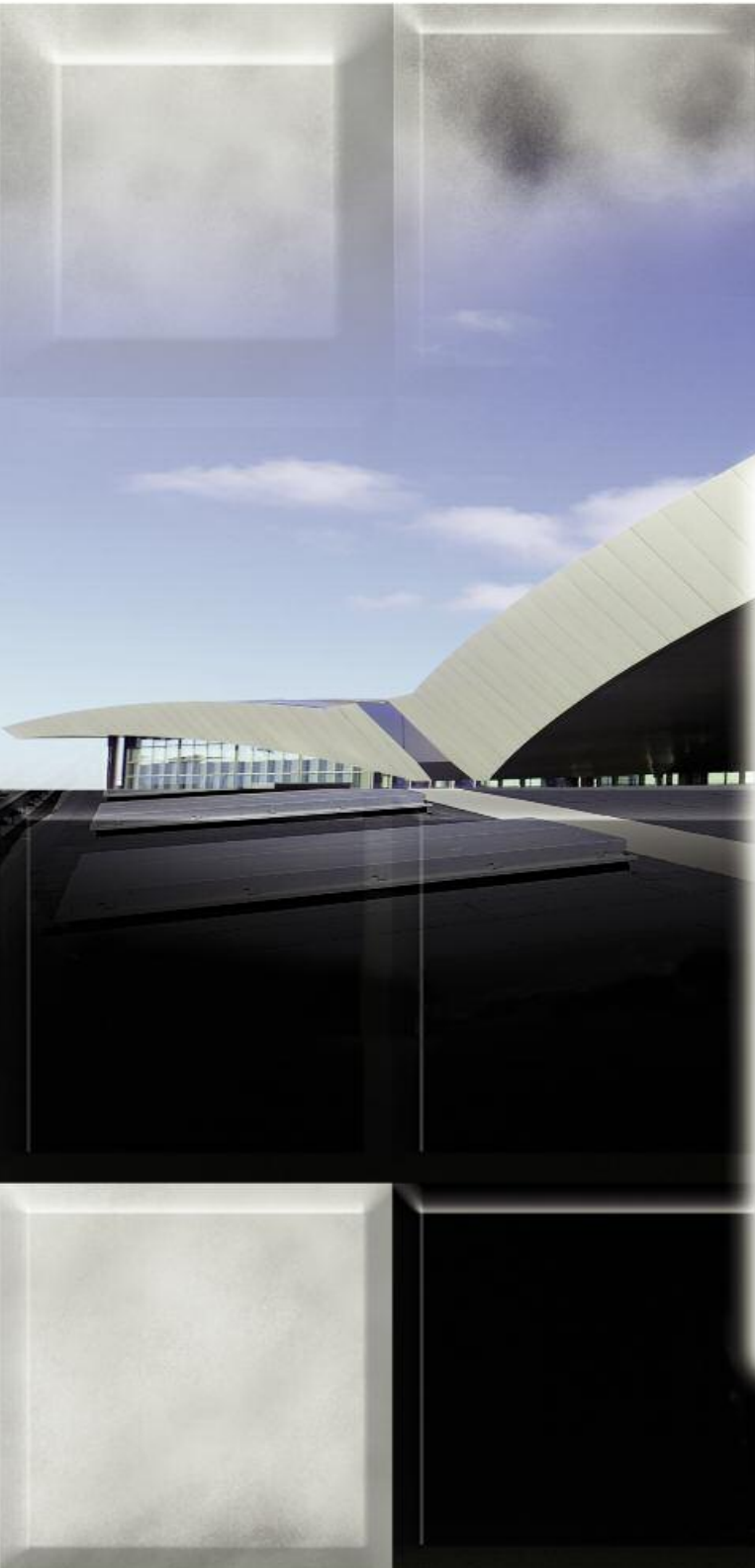

# Processing at a glance

## Cutting to shape



### Sawing see page 7

- with vertical panel saw, circular or jig saw

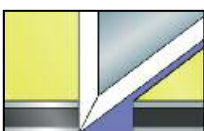

### Cutting see page 8

- with guillotine shears (slight drawing of the panel cover sheet), cushion clamp

## Punching / Decorative work

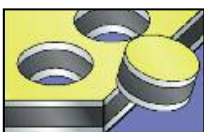

### Punching see page 8

- with conventional sheet punching machines. For clean cuts please use evenly ground tools. Drawing of the panel cover sheet

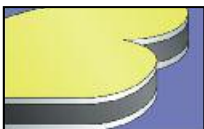

### Contour cutting see page 8

- with water torches, CNC machining centres and jig saws

## Shaping



### Bending see page 9

- with folding machine or bending press, min. inner radius  
 $r = 10 \times t$  ALUCOBOND® and ALUCOBOND® plus  
 $r = 25 \times t$  ALUCOBOND® A2  
 (t = panel thickness)  
 return travel greater than with solid sheet



### Roll bending see page 9

- with roll bending machines. Make sure to use ground rolls.



### Folding (routing technique) see page 11

- manually after routing a V-groove using a panel saw with routing device, a CNC machining centre or a panel routing machine

## Joining



### Drilling holes for jointing see page 8

- with drill bits for aluminium sheet and plastic panels (for larger holes use a drill bit with locating point)



### Riveting see page 16

- with normal tools and rivets or blind rivets

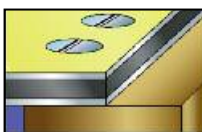

### Screwing see page 17

- with normal stainless steel screws or bolts for wood, sheet or metal



### Welding see page 18

- the PE core material with hot-air welding devices and PE welding rod



### Glueing see page 19

#### Outdoor use

- adhesive sealing compound

#### Indoor use

- metal adhesives for aluminium
- double-sided adhesive tape



### Clamp connections see page 19

- with toothed butt joint and corner sections for 3, 4 and 6 mm

## Surface treatment



### Lacquering see page 21

- overlacquering of ALUCOBOND® surfaces possible with suitable lacquer qualities

#### Note:

For processing ALUCOBOND® A2 and ALUCOBOND® plus please refer to separate leaflet.

# Contents

	Page
<b>Transport / Storage / Handling</b>	<b>4/5</b>
<b>Cutting and Fabricating</b>	<b>6 - 9</b>
<b>Routing and Folding Technique</b>	<b>10 - 13</b>
<b>Jointing / Fixing Technique</b>	<b>14 - 19</b>
<b>Surface Treatment</b>	<b>20/21</b>
<b>Cleaning and Maintenance</b>	<b>22/23</b>
<b>Technical Data sheets</b>	<b>24 - 26</b>
<b>ALUCOBOND® Information</b>	<b>27</b>



# Transport Storage Handling

ALUCOBOND® is a prefabricated panelling material, i.e. the surface of the standard panel is either lacquered, anodised or mill-finished. These surfaces are protected by a special foil during transport, storage and processing. Nevertheless, the following information must be observed when storing and handling the panels:

- The pallets must be handled carefully during transport and unloading. Do not handle open pallets.
- Upon delivery the pallets must be examined for any damage due to moisture (ALUCOBOND® panels that have become wet must be dried to avoid any spots or corrosion forming). Any damage must be reported immediately and confirmed by the forwarding agent.
- Store the pallets so that they are protected against any wetness penetrating due to rain and spray water and avoid any condensation forming (e.g. when transporting cold panels to warmer rooms).
- Store the pallets stacked one over the other (do not store ALUCOBOND® panels standing vertically), with a maximum of 6 pallets of the same format stacked on top of each other (heavy pallets at the bottom).
- Individual panels must be lifted off the pallet by two people holding all four corners and not drawn over each other. Carry the panels vertically. Wear gloves to avoid staining.
- If stacking panels, nothing should be put in between to avoid markings.

## **The following should be observed as regards the ALUCOBOND® protective foil:**

- Storage exceeding 6 months should be avoided.
- Strong fluctuations in temperature reduce the long-term durability.
- Do not mark the panel surface or protection film with inks (markers), tapes or labels. Solvent or plasticiser may penetrate the film and affect the lacquered surface.
- Should the protective foil partially come off during processing, dirtied edges can occur in the course of time.
- Remove protective film as soon as possible after erection. Protective film that remain on panels for an extended period of exterior exposure may be very difficult to remove.



# Cutting and Fabricating

## Sawing

### Carbide tipped (CT) saw blades

Blade geometry	Tooth thickness approx. 2 – 4 mm, tapered to the inside to prevent jamming
Tooth geometry	trapezoid tooth / flat tooth
Pitch	10 – 12 mm
Clearance angle	15°
Rake angle	10° positive
Maximum cutting speed	5,000 m/min
Maximum feed	30 m/min

### Carbide tipped (CT) saw blades for HOLZ-HER and Striebig circular panel saws

#### Trapezoid/flat tooth saw blade, flat teeth 45° chamfered for burr-free edges

Saw blade dia.	D = 300 mm (for Striebig vertical panel saw Standard II)
Number of teeth	t = 72 (for cuts of up to 5 panels) LEUCO Code No. 181724 t = 96 (for single cuts without burrs) LEUCO Code No. 181725
Saw blade dia.	D = 250 mm (for Holz-Her vertical panel saw 1255 ALUCOBOND®)
Number of teeth	t = 60 (for cuts up to 5 panels) LEUCO- Code No. 181726 t = 80 (for cuts without burrs) LEUCO- Code No. 181727
Bore dia.	D = 30 mm
Tooth thickness	3.2 mm
Clearance angle	15°
Rake angle	10° positive

#### Manufacturer / supplier:

Leuco  
Ledermann GmbH & Co.KG  
Phone +49 74 51 93 -0  
Fax +49 74 51 93 -270  
E-Mail info@leuco.com  
www.leuco.com

#### Sketch showing the edge geometry for professional reshaping:

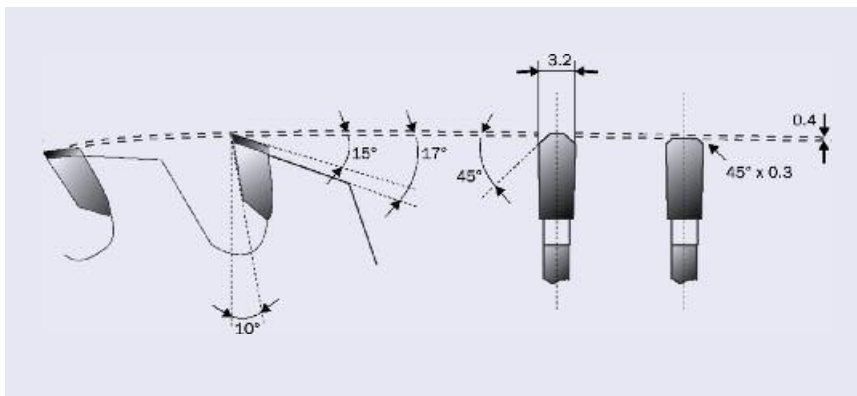

### Jig saw blades

for wood or plastics, e.g. T101 B (Bosch), tooth thickness 2.5 mm for precision cuts

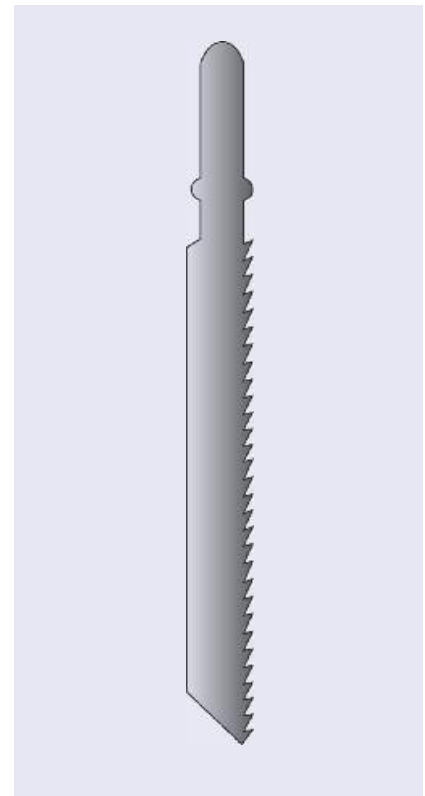

### Saw blades for ALUCOBOND® A2 and ALUCOBOND® plus

for max. number of revs 2,500 Rpm  
Tooth geometry see above  
Saw blade dia. D = 300 mm  
(for Striebig Saw Standard II)  
Number of teeth t = 72  
Speiser Code No. 07060651  
Saw blade dia. D = 250 mm  
(for Holz-Her Saw 1255)  
Number of teeth t = 60  
Speiser Code No. 02040151

#### Manufacturer / supplier and Sharpening service

Speiser Werkzeugvertriebs-GmbH  
Phone +49 74 56 94 49 0  
Fax +49 74 56 94 49 11

For further information on machines and tools please refer to the separate leaflet on 'Processing of ALUCOBOND® A2 and ALUCOBOND® plus'.

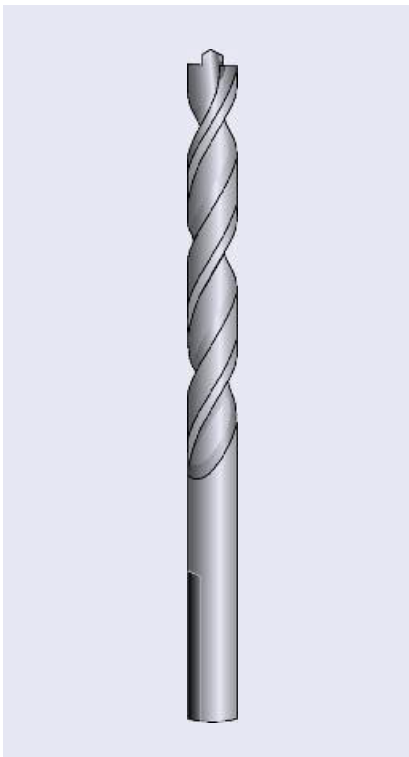

## Routing

ALUCOBOND® can be easily routed on conventional routing machines and CNC machining centres.

To avoid pressure marks on the ALUCOBOND® surface, please use plastic or wood vice jaws when chucking the workpieces.

High-speed steel or carbide tipped cutters suitable for aluminium and ALUCOBOND® have a wide tooth pitch, radiused and smooth grooves and small lip angles.

They produce perfect cuts, e.g. under the following conditions:

- High-speed steel  
max. cutting speed max. 3,000 m/min.  
feed max. 25 m/min.
- Carbide tipped cutter  
max. cutting speed max. 5,000 m/min.  
feed max. 30 m/min.

Suitable end milling cutters for ALUCOBOND®:

Carbide end milling cutter serie F 113

### Manufacturer / supplier:

GIS Gienger Industrie-Service  
Tel. +49 74 61 16 20 -20  
Fax +49 74 61 16 20 -21  
www.gis-tec.com

## Drilling

ALUCOBOND® can be drilled with twist drills normally used for aluminium and plastics on machines common for metals.

Drill material:  
High-speed steel (HSS)

Tool geometry:  
Lip angle: 100° – 140°

Drilling without burr is possible using the following drills:

spot facing cutter with centre-point.

Angle of whist: 30° – 45°

e.g. Extreme 2™ HSS-G Metal drill DIN 338 of De WALT, D-Idstein

## Countersink

Three-lipped core drills and counterbores common for aluminium are used for countersinking pre-drilled holes. Counterbored holes are less out of centre than those produced by twist drills. Countersinks for aluminium can be used for countersinking flat head screws into ALUCOBOND®. Head and shank counterbores for aluminium are mainly used for countersinking screw heads or for making holes through ALUCOBOND®.

## Counter cutting

ALUCOBOND® can be cut to size with jig saws, CNC machining centres and water torches. Please cut abrasively when using a water torch. Pre-drilling of the panels is necessary when starting the cut in the middle of a panel as it is not possible to drill through with a water torch.

## Shearing

ALUCOBOND® can be cut with a conventional guillotine. A shearing angle of  $\leq 1.5^\circ$  and a small shearing clearance (paper test) are necessary to achieve an optimum cutting quality. To prevent damage to the cover sheet, make sure to use shock-absorbent rubber pads between the clamp and the ALUCOBOND® surface.

### Important:

For applications with visible cutting edges (e.g. riveted façades) shearing of ALUCOBOND® pre-cut sheets is not suitable for decorative use and should be avoided.

## Punching

ALUCOBOND® panels of any thickness can be punched with conventional sheet punching machines. For clean cuts please use evenly ground tools and the narrowest possible cutting gap (0.1 mm). This punching method also causes a slight drawing of the panel cover sheet. Holes of a minimum diameter of 4 mm can be punched. The minimum width of web between hole edges is also 4 mm.

## Bending

ALUCOBOND® can be formed by conventional metal and plastic fabrication methods. Certain specific points should be noted relating to the multilayer structure combining materials of different characteristics:

- The minimum radius is for ALUCOBOND® and ALUCOBOND® plus  $r = 10 \times t$   
for ALUCOBOND® A2  $r = 25 \times t$   
 $t =$  panel thickness

The spring-back effect experienced when folding sheet metal is larger with ALUCOBOND®. For production series a prototype should be made.

The surface should be protected from damage by affixing plastic film or inserting polyethylene of 1 – 2 mm thickness or plastic film strips during processing.

The panel surface must be free from any adhesive material (e.g. labels, etc.).

### Important:

When bending ALUCOBOND® with an anodized surface, the bent area is brighter.

## Bending with a brake press

(Fig. 1)

ALUCOBOND®, like sheet metal, is easily formed with a brake press. The air-bending process is used when forming with a brake press.

The ALUCOBOND® panel rests on the edges of the die (rails, channels) and is bent by the punch (tube or shaft). The bending angle is determined by the width of the die and the stroke of the punch. The die edges should be rounded and smooth.

Ideal die width:

$2 \times t + 2 \times$  protective foil thickness + punch diameter + 15 mm

The minimum side length of the bent part should be 5 times the ALUCOBOND® thickness.

## Bending with a folding machine

(Fig. 2)

When working with folding machines, the panel to be bent is clamped between two cheeks. The projecting edge is bent around the upper clamping cheek and former using the movable swivel bar. The bending radius is determined by interchangeable formers attached to the upper clamping cheek.

## Bending with a roll bending machine

ALUCOBOND® can be bent with sheet metal roll bending machines – mainly with three and four-roll machines. Please make sure that the feeder does not exert too much pressure.

Bending rolls which are also used for bending other metals must be thoroughly cleaned from swarf before processing ALUCOBOND®. We recommend ground rolls to avoid damaging the cover sheets.

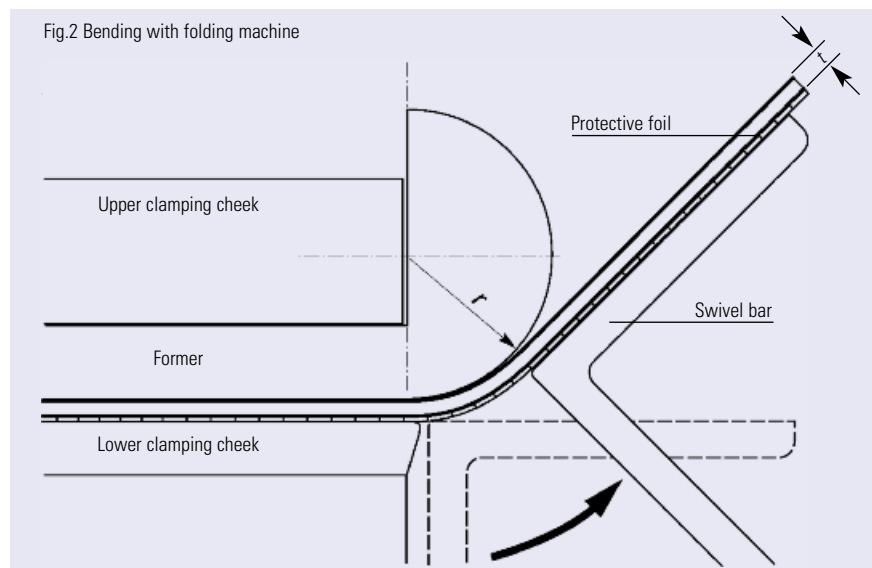
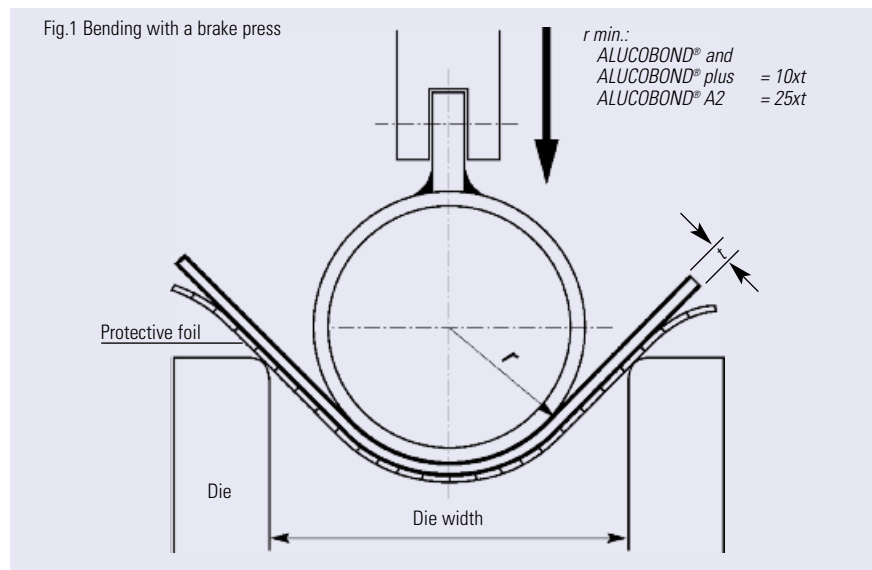

### Note:

For processing ALUCOBOND® A2 and ALUCOBOND® plus please refer to the separate leaflet.



# Routing and Folding Technique for individual Shaping and Design

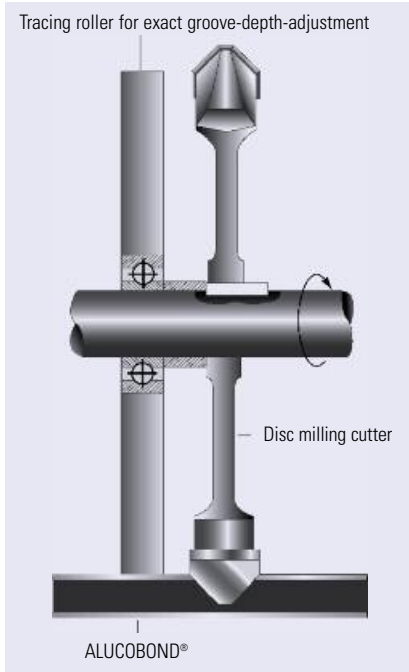

## Method

ALUCOBOND® composite panels can be shaped by means of a simple processing technique. This procedure, the routing and folding technique, enables a variety of shapes and sizes to be manufactured.

V-shaped or rectangular grooves are routed on the rear of the panels with disk or end milling cutters, whereby the aluminium cover sheet at the front and part of the polyethylene core are retained. The small thickness of the remaining material then allows folding by hand. A brake press is not required. The groove shape determines the radius of the bend.

The grooves can be produced with a panel saw with routing device for ALUCOBOND®, on a CNC machining centre, with a panel routing machine or a hand routing machine. The routing and folding technique can be used for composite panels of all standard surfaces.

### Important:

When folding ALUCOBOND® with an anodized surface, the edges are brighter.

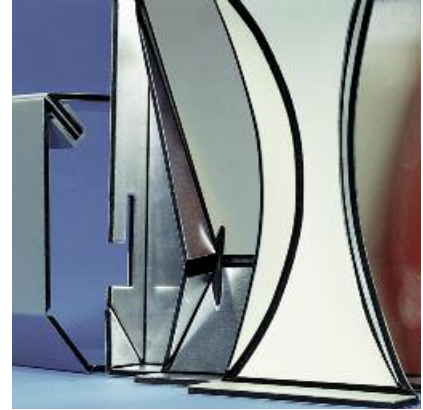

## Advantages

The convincing advantages of the routing and folding techniques are:

- Minimum investment
- Simple operating technique
- Folding need not be done in the workshop, it can be done on site; this means low transport and storage costs
- Low-cost manufacture of shaped parts like fascia claddings, roof edgings, corner pieces, column casings and many more are possible
- Versatile formability
- Good economy
- Shapes are not restricted by machine dimensions
- Folding without cutting, therefore no buckling in the corner area and thus even elements

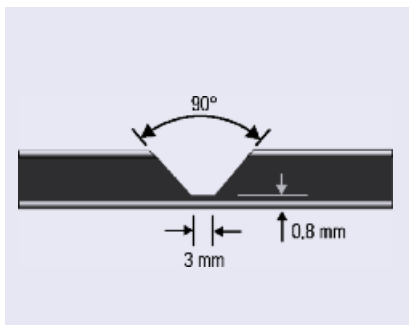

Groove (V-shaped) for edges up to 90°

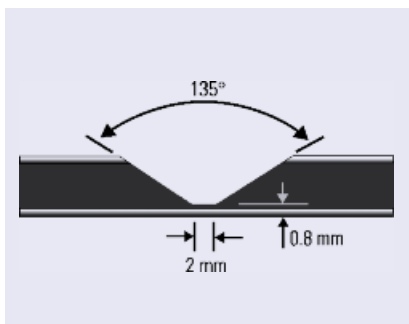
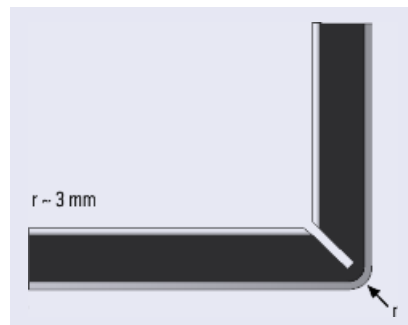

Groove 135° (V-shaped) for edges up to 135°

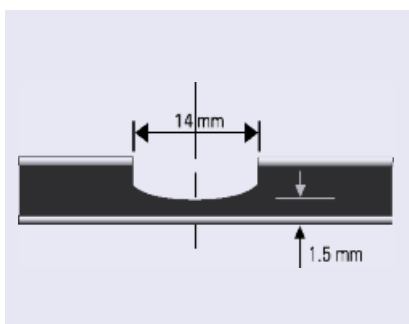
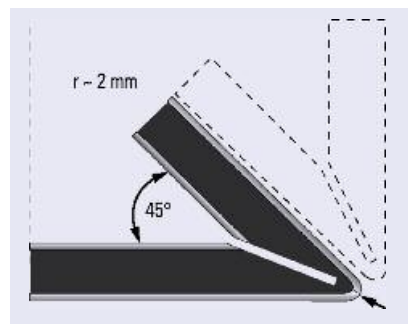

Rectangular groove for edges up to 180° depending on panel thickness

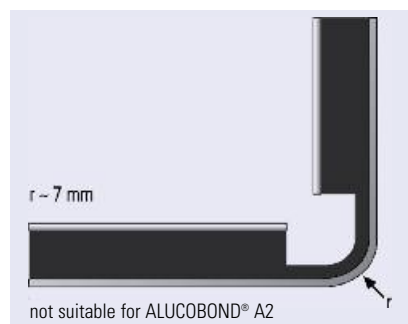

# Tools and machinery for routing and folding technique

## Panel saws ALUCOBOND® routing device (special accessory)

Holz-Her vertical panel saw  
PK 1255 ALUCOBOND®  
Code No. 278.6133

Striebig Vertical panel saw  
Standard II for composite panels

**Manufacturers / suppliers:**  
Reich Spezialmaschinen GmbH  
Phone +49 7022 7 02 - 0  
www.holzher.de

Striebig AG Maschinenbau  
Phone +41 41 250 02 57  
www.striebig.com

Other panel saws can subsequently be provided by the manufacturer with an additional routing device. Please ask for details.

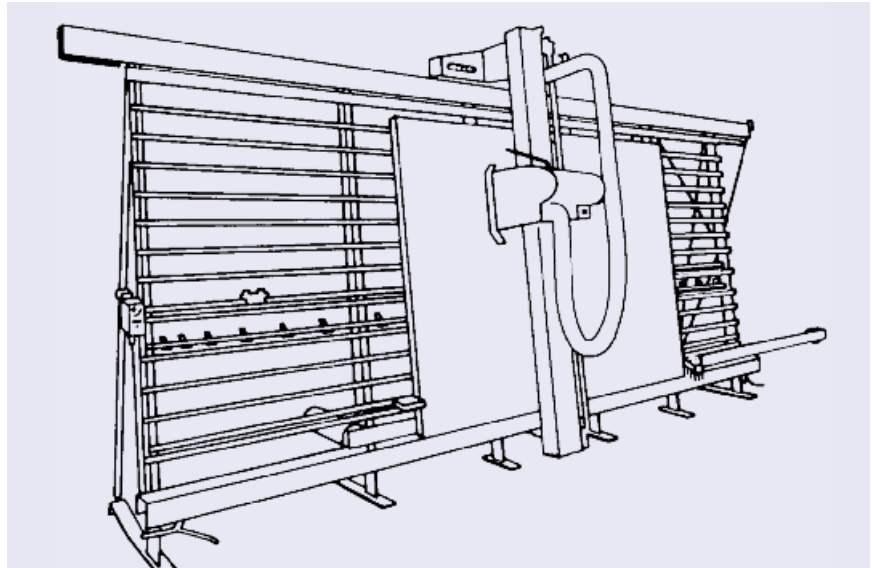

## CNC machine centres

**Manufacturers / suppliers:**  
On request.

## Panel routing machine PF 1200 E-Plus ALUCOBOND®

(Fig. 1)

Supplied with:

- Tracing roller for 4 mm
- Cutter disk for V-grooves 90°
- Adjustment template
- Transport box

**Supplier:**

TTS Tooltechnic Systems Deutschland GmbH  
Marketing sales: FESTOOL  
Phone +49 7024 804 - 640  
Fax +49 7024 804 - 724  
ebg@tts-festool.com  
www.festool.com

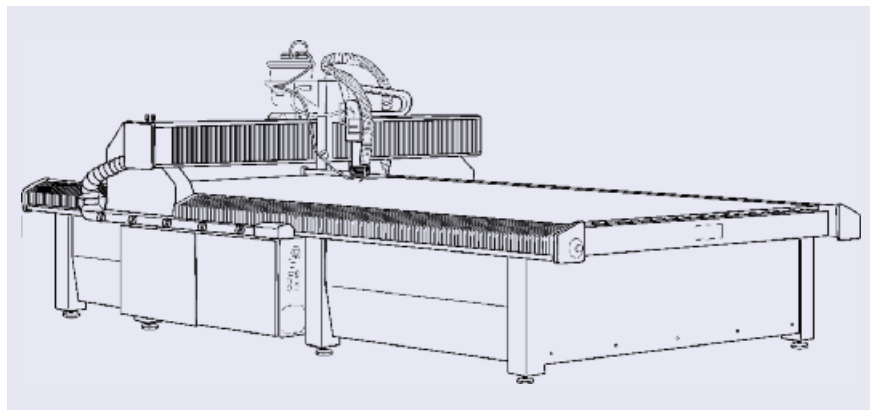

## Hand routing machines

(Fig. 2)

Commercially available hand routing machines with a minimum rating of 800 W are suitable. Collet chucks 8 mm dia.



## Carbide tipped disk milling cutters for vertical panel saws

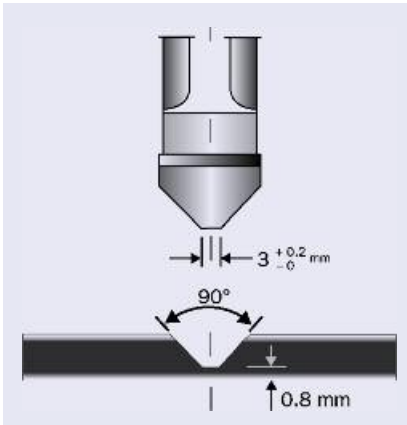

Disk milling cutter for V-grooves 90°

The diameters of tracing rollers and cutter discs are adjusted so as to leave a residual core thickness of 0.3 mm (V-groove) or 1 mm (rectangular groove). The dimensions given in the drawings show the cover panel thickness of 0.5 mm plus the corresponding residual core thickness.

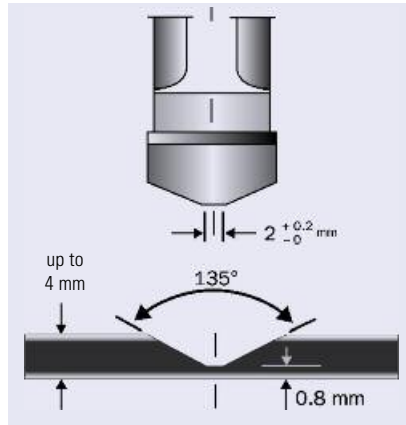

Disk milling cutter for V-grooves 135°

Please address all enquiries relating to

- new machines with accessory parts for milling of ALUCOBOND®
- possible retrofitting of existing machines (stating machine type/No. and year of construction)
- accessories such as cutter disks, tracing rollers, etc.

directly to the manufacturer of the panel saws.

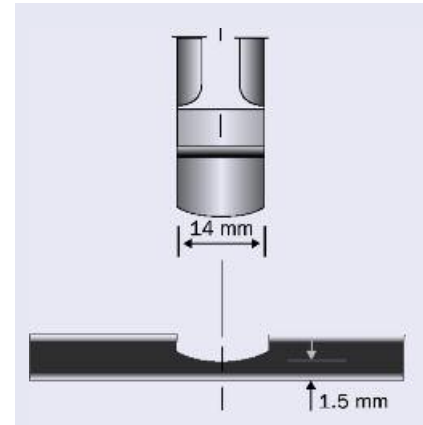

Disk milling cutter for rectangular grooves

### Important:

Please state the following in your enquiry or order "for processing ALUCOBOND® composite panels".

## Milling cutters with cylindrical shank for hand routing machines

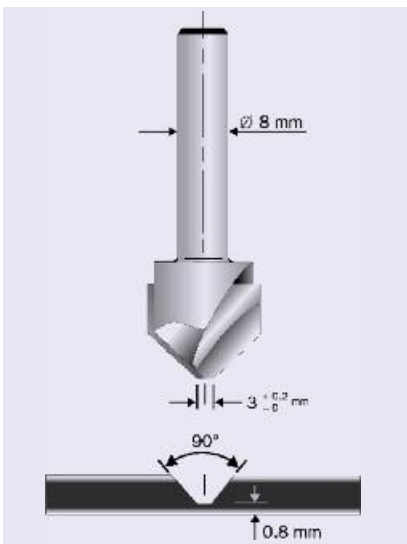

End milling cutter for V-grooves 90°

Carbide tipped cutter No. 491444 (Festool)  
Carbide tipped cutter No. FV09.01.090 (GIS)  
Carbide tipped cutter No. 79 803 (KWO)

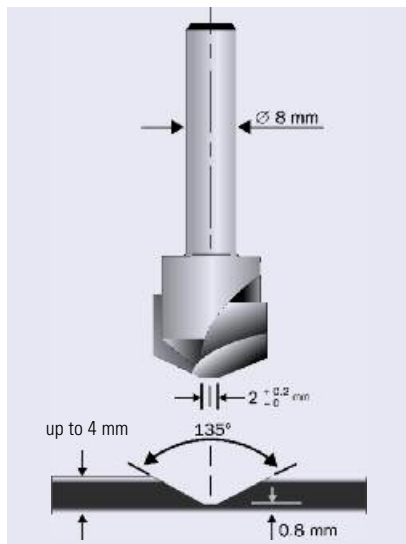

End milling cutter for V-grooves 135°

Carbide tipped cutter No. 491443 (Festool)  
Carbide tipped cutter No. FV09.01.135 (GIS)  
Carbide tipped cutter No. 79 804 (KWO)

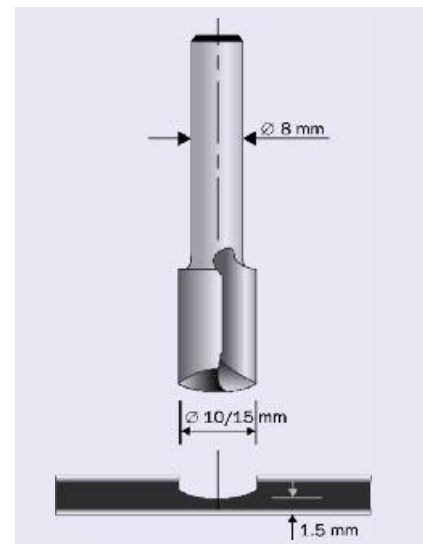

End milling cutter for rectangular grooves

HSS cutter  $\varnothing$  10 mm No. 79800 (KWO)  
HSS cutter  $\varnothing$  15 mm No. 79801 (KWO)

### Suppliers for profile cutters

TTS Tooltechnic Systems Deutschland GmbH  
Marketing sales: FESTOOL  
Phone +49 70 24 80 47-89  
Fax +49 70 24 80 47-24  
E-Mail asem@tts-festool.com  
www.festool.com

GIS Gienger Industrie-Service  
Phone +49 74 61 16 20-20  
Fax +49 74 61 16 20-21  
www.gis-tec.com

KWO-Werkzeuge GmbH  
Phone +49 73 26 96 42-0  
Fax +49 73 26 96 42-10  
E-Mail info@kwo.de  
www.kwo.de  
(not available ex stock)

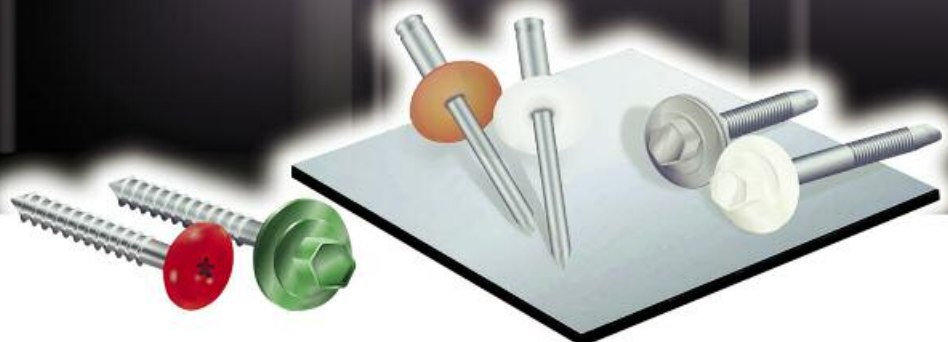
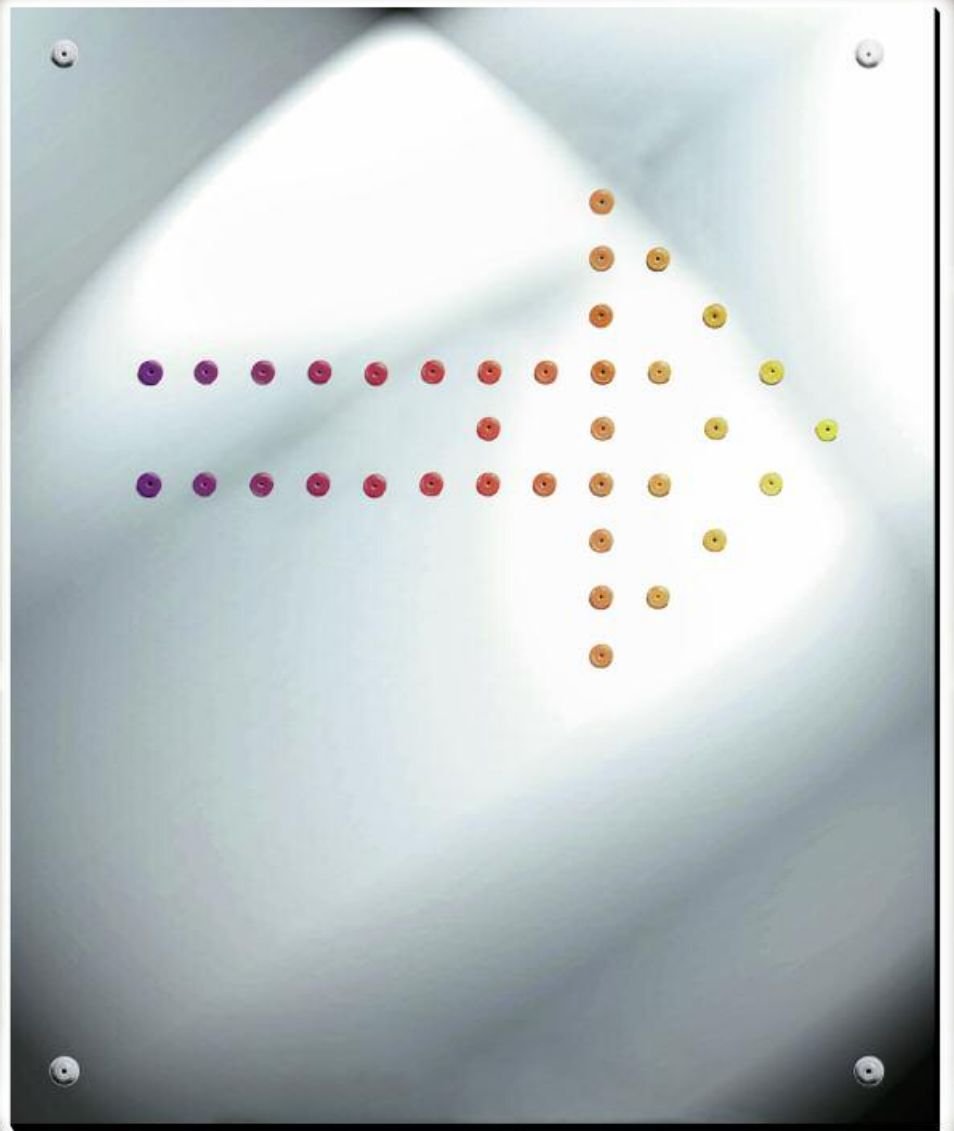

# Jointing / Fixing Technique

ALUCOBOND® can be joined by means of standard processes used in metal and plastics technology.

If ALUCOBOND® is to be joined to structural parts of metals other than aluminium, or if fasteners (e.g. bolts, screws) are to be used, the following material guidelines should be observed:

Fasteners and structural parts made of aluminium, plastic or stainless steel should be suitable for the assembly with ALUCOBOND®.

When using other materials please insert insulating washers etc. or apply protective coating to prevent corrosion.

Please take the thermal expansion of the panel into account for outdoor use of ALUCOBOND® to avoid jamming or deformation.

The minimum gap depends on the expected expansion of the panel.

Please refer to processing recommendations for rivets and bolts for additional measures to prevent jamming.

The linear thermal expansion of ALUCOBOND® is determined by the aluminium cover sheets.

**At a temperature difference of 100°C the longitudinal expansion is 2.4 mm/m.**

# Riveting

ALUCOBOND® panels can be fastened together or joined to other materials with rivets common to aluminium constructions.

For outdoor use and for use in areas of high humidity, aluminium blind rivets with stainless steel mandrels should be used to prevent ugly corrosive edges. When using aluminium blind rivets with steel mandrels, the mandrel should drop out after riveting (detachable version). Countersunk rivets are suitable for indoor use only.

## For outdoor use please note:

- For outdoor use aluminium blind rivets that have been approved for construction with a 5 mm shaft diameter and an rivet head diameter of 11 or 14 mm are used.
- Please take the thermal expansion of the panel into account (2.4 mm/m/100°C). To avoid jamming, the hole in the panel must be large enough to allow for expansion.
- With the shaft of the rivet fitting closely to the edge of the hole, the rivet head must cover over 1 mm of the area surrounding the hole.
- Multi-step drills or hole gauges having corresponding diameters are used for centrally drilling holes into the panel and the substructure and for centrally fitting the rivet.
- Rivet attachment jigs are used for fitting blind rivets without jamming allowing for a tolerance of 0.3 mm. Make sure to use rivet attachment jigs and rivets from the same manufacturer, as the height of the rivet head according to DIN 7337 may vary.
- The clamping thickness results from the thickness of the material to be riveted plus an additional value of 2 mm to ensure that the closing head is perfectly formed. In accordance with this clamping thickness the corresponding shaft length is determined in the tables provided by the rivet manufacturers. (min. = 14 mm)

## Important:

Since during riveting many factors may have an influence on the exact tolerance of the rivets of 0.3 mm (e.g. rivet head tolerance), we recommend that you make a test on a façade panel.

Please always remove the protective foil in the riveting area prior to riveting.

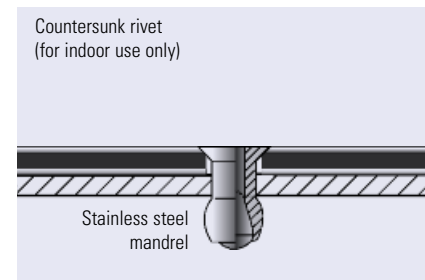
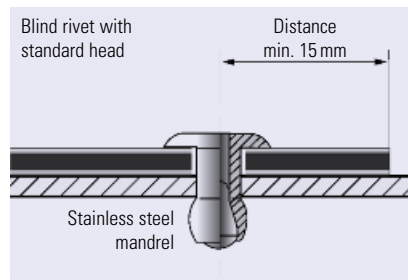
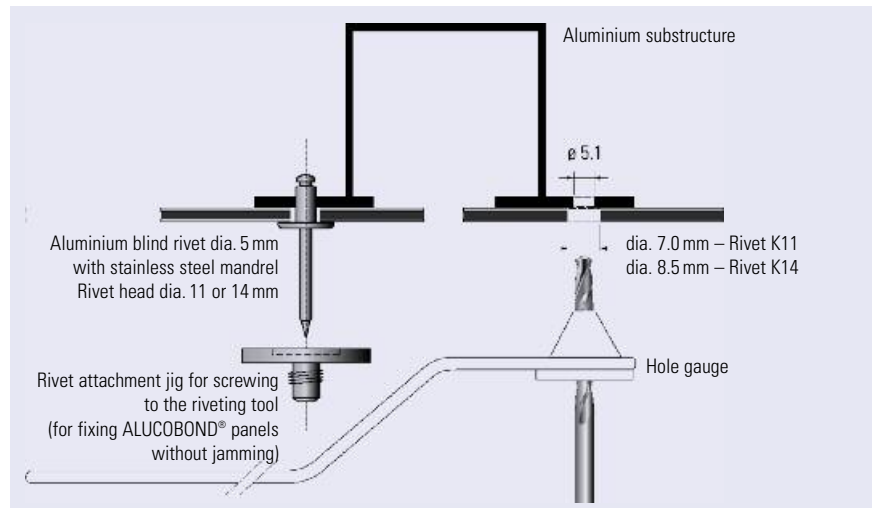
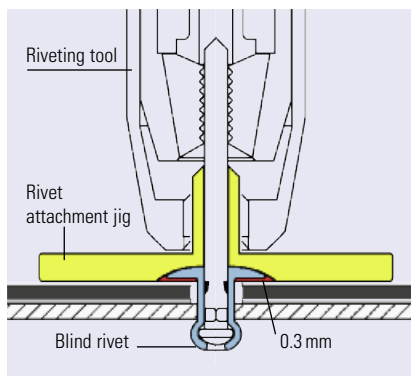

## Manufacturers / suppliers:

### Blind rivets

In the trade or from:

GESIPA-Blindniettechnik GmbH  
Phone +49 61 05 962 - 0  
Fax +49 61 05 962 - 287  
www.gesipa.com

Gebr. Titgemeyer GmbH & Co. KG  
Phone +49 541 58 22 - 0  
Fax +49 541 58 22 - 490  
www.titgemeyer.de

VVG-Befestigungstechnik GmbH & Co.  
Phone +49 43 21 96 71 - 71  
Fax +49 43 21 96 71 - 96  
www.vvg.de

### Blind rivets lacquered

MBE GmbH  
Phone +49 23 73 17 430 - 0  
Fax +49 23 73 17 430 - 11  
www.mbe-gmbh.com

SFS intec GmbH  
Phone +49 61 71 70 02 - 0  
Fax +49 61 71 70 02 - 46  
www.sfsintec.biz

### Multi-step drills (not available ex stock)

KWO Werkzeuge GmbH  
Phone +49 73 26 96 42 - 0  
Fax +49 73 26 96 42 - 10  
www.kwo.de

### Hole gauges

Please refer to blind rivets lacquered: MBE GmbH

### Rivet attachment jigs

Appropriate rivet attachment jigs are available from the manufacturers or suppliers of rivets.

# Threaded fasteners

## Threaded fasteners for outdoor use

Please take the thermal expansion of the panel into account when using threaded fasteners outdoors. To avoid jamming, the hole diameter in the panel must allow for the expansion.

Fastening without jamming is possible with fascia screws made of stainless steel with sealing washer (Fig. 1) that have been approved for construction. The screws must be suitable for the corresponding substructure (please note the information given by the manufacturer). The screws should be tightened with a torque wrench or screwdriver so that the sealing washer is placed on the panel for sealing the bore hole without exerting pressure onto the panel.

Multi-step drills or hole gauges having corresponding diameters are used for centrally drilling holes into the panel and the substructure and for centrally fitting the rivet.

### Important:

Make sure to remove protective foil prior to screwing.

## Threaded fasteners for indoor use

Screws for sheet metal and wood with different head-shapes are suitable for indoor use (Fig. 2). They do not normally allow for any panel expansion.

Countersunk screws can be inserted by the usual countersinking method or by depressing the aluminium surface into the panel. When depressing the aluminium surface, the hole diameter in the panel must be larger than the screw diameter.

### Manufacturers /Suppliers:

#### Fascia screws

EJOT Baubefestigungen GmbH  
Phone +49 27 52 908 - 0  
Fax +49 27 52 908 - 731  
www.ejot.de

#### Fascia screws, lacquered

MBE GmbH  
Phone +49 23 17 430 - 0  
Fax +49 23 17 430 - 11  
www.mbe-gmbh.com

#### SFS intec GmbH

Phone +49 61 71 70 02 - 0  
Fax +49 61 71 70 02 - 46  
www.sfsintec.biz

Fascia screws for metal substructures

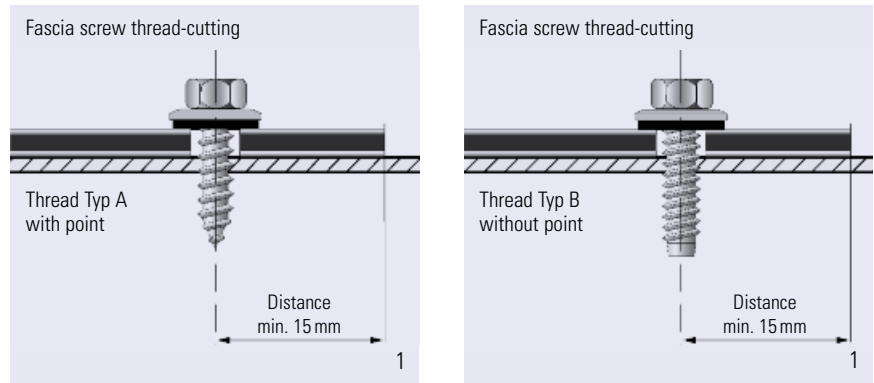

Screws for indoor use – no outdoor use

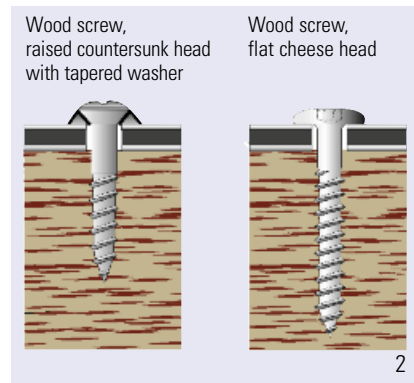
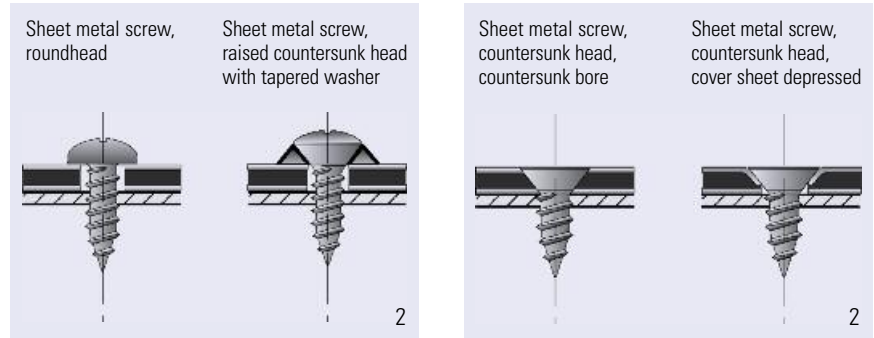

### Plastic covers for screws

HA-WI Kunststoffe GmbH & Co. KG  
Phone +49 27 54 37 46 226  
Fax +49 27 54 81 19  
www.ha-wi.com

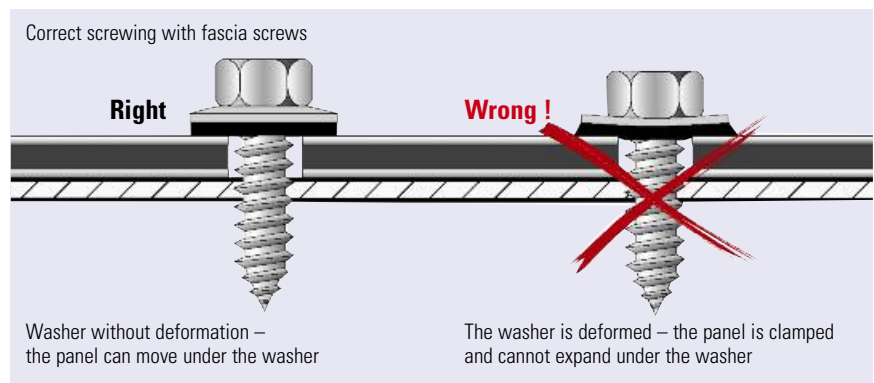

# Hot-air welding (for ALUCOBOND® with PE core only)

Hot-air welding has proved useful for joining thermoplastic plastics and for welding ALUCOBOND®. The plastic core and the plastic welding rod are heated and welded with electrical hot-air welding sets. The following conditions are essential for good results:

- Well prepared welding joint
- Good quality welding rod
- Clean hot air
- Correct temperature
- Correct contact pressure
- Welding speed

## Welding with rapid welding nozzle

(Fig. 1)

The rapid welding nozzle method ensures uniform heating of the core material and the welding rod and thus results in a better welding quality.

Rod A is inserted manually through nozzle tongue B. By applying constant pressure to the nozzle tongue, the rod is pressed into the joint.

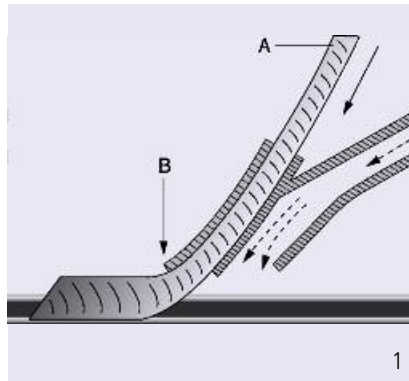

## Preparing of welding joint

For butt-welding, the edges of the ALUCOBOND® panels must be chamfered (Fig. 2).

Before folding and welding ALUCOBOND® panels, grooves have to be routed into the panels using corresponding milling cutters (Fig. 3).

As the plastic core oxidizes relatively quickly when exposed to air, welding should be completed within 24 hours after chamfering.

## Welding rod

**Please use the following quality:**  
**Polyethylene, soft, Type: 1800-h**  
**Colour: black, diameter: 3-4 mm**

The outer layer (oxide layer) of the welding rod should be removed with emery cloth immediately before welding. Please chamfer the starting end of the rod to approx. 45°.

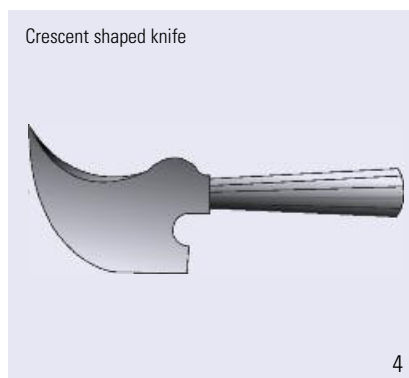
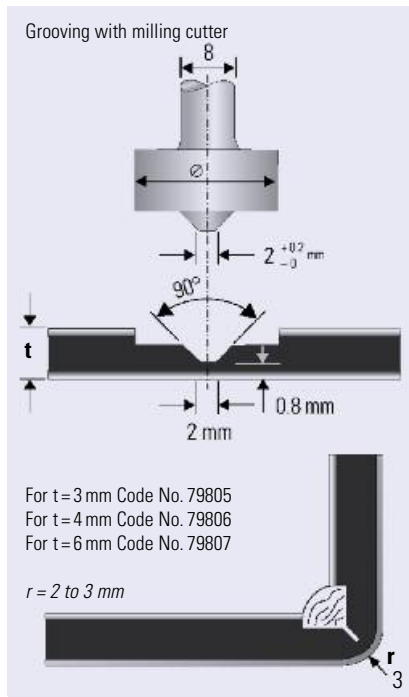
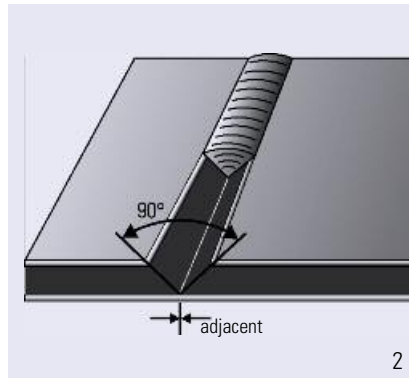

## Temperature

The following air temperature is required for hot-air welding:

ALUCOBOND®: 265°C +/- 5°C

The temperature must be continuously adjustable and is measured with a mercury thermometer or bimetal measuring unit 5 mm from the nozzle point. To measure the temperature, please take off the rapid welding nozzle.

## Contact Pressure

The required pressure to the nozzle shoe (rapid welding nozzle) should be approx. 3 kp.

## Hot-air welding sets

We recommend that the Leister hot-air welding set, Type DIODE PID, be used in connection with the ventilator, Type MINOR.

## Skimming the welding seam

A scraper blade or knife is used at a very flat angle to shave the welding seam as soon as it has cooled down. For visible welding joints, the seam on butt and corner welds is removed using a crescent-shaped knife (Fig. 4).

## Manufacturer / Suppliers:

### Hot-air welding sets, temperature measuring devices, crescent-shaped knives and welding rod

Heißlufttechnik Flocke GmbH  
 Leister-Vertrieb  
 Phone +49 2 12 38 260 - 0  
 Fax +49 2 12 31 23 24  
[www.heisslufttechnik.de](http://www.heisslufttechnik.de)

Leister Process Technologies  
 Phone +41 21 23 74 - 74  
 Fax +41 21 23 74 - 16  
[www.leister.com](http://www.leister.com)

### Welding rod

Ketterer + Liebherr GmbH & Co KG  
 Phone +49 7 61 4 78 14 - 0  
 Fax +49 7 61 4 78 14 - 90  
[www.ketterer-liebherr.de](http://www.ketterer-liebherr.de)

### Milling cutters (not available ex stock)

KWO Werkzeuge GmbH  
 Phone +49 73 26 96 42 - 0  
 Fax +49 73 26 96 42 - 10  
[www.kwo.de](http://www.kwo.de)

# Glueing

## Metal adhesives / Universal adhesives

For indoor use, trade fair/exhibition stand structures and machines, most metal or universal adhesives are suitable.

## Tapes / Velcro tapes

Double-sided tapes (such as the 3M-VHB high capacity jointing systems) can be used for the above applications with low tensile or transversal strength requirements. Velcro tapes are available for detachable joints, for example SCOTCHMATE or tapes marketed under the Dual Lock trademark.

Both products are also available from 3M Deutschland GmbH  
 Phone +49 21 31 14 - 0  
 Fax +49 21 31 14 - 26 49  
[www.3m.com](http://www.3m.com)

## Adhesive sealing compounds

For high-strength and elastic connections we recommend the following one-component adhesive sealing compound:

Sika Bond-T2 (polyurethane base)  
 Sika GmbH  
 Phone +49 71 25 9 40 - 0  
 Fax +49 71 25 9 40 - 321  
[www.sika.de](http://www.sika.de)

For outdoor use, this adhesive can be used for fastening parts of minor static importance.

### Important:

Please observe the manufacturer's instructions regarding the application and use of adhesives/tapes.

Adhesives and sealing compounds do not adhere to the ALUCOBOND® plastic core (cut edges).

Laminating of ALUCOBOND® panels to other materials may result in deformation of the laminates (differing expansion/bimetal effect).

# Clamp connections

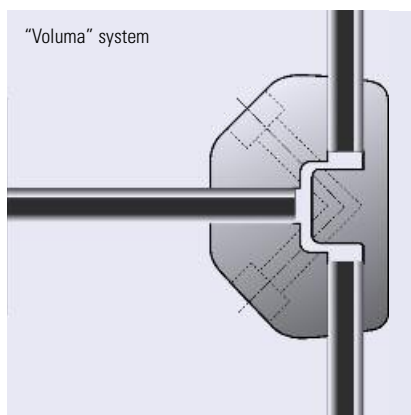
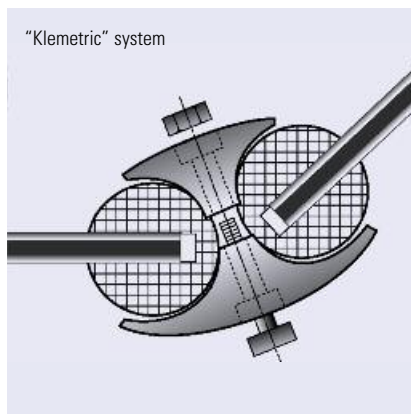

Clamp connections incorporating aluminium or plastics are particularly suitable for ALUCOBOND®. They generally consist of two parts with the clamping effect achieved by bolting.

Various designs of clamping elements are used for display and store fitting purposes (no outdoor use).

### Suppliers:

"Klemetric" system:  
 KlemProducts®Gesellschaft für Werbemittel mbH  
 Phone +49 89 857 72 80  
 Fax +49 89 895 83 48  
[www.klemproducts.de](http://www.klemproducts.de)

"Voluma" system:  
 MERO Raumstruktur GmbH & Co.KG  
 Ausstellungssysteme  
 Phone +49 931 66 70 - 571  
 Fax +49 931 66 70 - 189  
[www.mero.de](http://www.mero.de)

Any suitable connection or shock-resistant frame can easily be made with aluminium sections.

The inevitable tolerances signify different retention forces. A uniform and solid fit of the sections is obtained by pressing the section sides together prior to inserting the panels.

Butt joint, corner and edge sections are available for panels of 3, 4 and 6 mm. Please ask for our stock list.

For fascia cladding applications special aluminium sections are provided for clamp connections.

For further information on ALUCOBOND® special sections and types for fascia claddings please ask for the respective documentation.

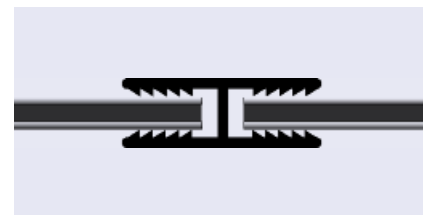
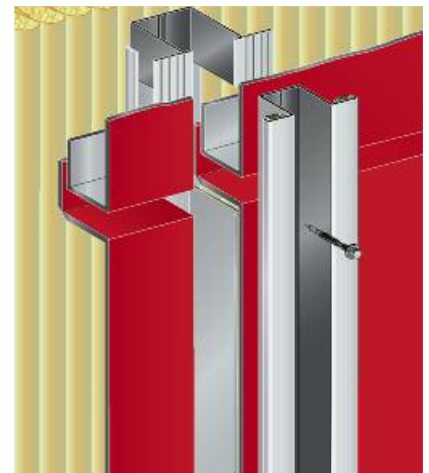



# Surface treatment

## Overlacquering of stove-lacquered ALUCOBOND® surfaces

Customer requirements for special colour shades of ALUCOBOND® composite panels are met in small amounts at our plant by overlacquering standard stove-lacquered ALUCOBOND® surfaces or mill-finished surfaces.

### Please note:

- **The maximum permissible temperature of the material (ALUCOBOND® panels) must not exceed 70°C when applying fast-drying methods. During the drying process at high temperatures the ALUCOBOND® panels must be positioned with great care to prevent deforming.**
- ALUCOBOND® cut edges should not be in contact with organic solvents for a prolonged period of time to avoid weakening the bond.
- ALUCOBOND® panels lacquered or overlacquered at a later stage should not be bent or folded. The lacquer in the bends or folds may be damaged due to the low elasticity of the top coat.
- Upon request, we can name you lacquer suppliers who are able to apply lacquer that can be bent and folded.
- Only inferior lacquer adhesion can be achieved on core material exposed at cut edges.
- Please make a test prior to overlacquering and follow the instructions of the lacquer suppliers.

## Lacquering of mill-finished ALUCOBOND® surfaces

The composition of lacquer coating for ALUCOBOND® is basically the same as those for mill-finished aluminium surfaces. However, it is advisable to be familiar with coating systems and materials as well as working methods for aluminium.

### Please note:

- For general information on painting, lacquering and coating of aluminium we recommend the leaflets on "02, 03, 012, 015 surfaces" issued by

Gesamtverband der Aluminiumindustrie e. V.  
Phone +49 211 47 96 0  
Fax +49 211 47 96 408  
[www.aluinfo.de](http://www.aluinfo.de)



# Cleaning and Maintenance of stove-lacquered Surfaces

Expert and regular cleaning not only maintains the aesthetic and representative finish of stove-lacquered surfaces, but also preserves their value and service life by removing dirt and aggressive deposits that are not washed away by rainwater.

## Annual inspection

The inspection of roofing and walls should take place at least once a year. This will depend on local environmental conditions.

## General instructions

- Remove leaves, grass and other objects.
- Remove
  - any parts clogging the roof gutter to avoid overflow;
  - any accumulation of dirt from wall areas that are inaccessible for rainwater (e.g. roofing).

These areas not only impair the physical appearance of the building but can also result in a premature deterioration of the coating.

- Make sure to check the condition of joint sealers, holders/supports and decorative parts on the building to prevent any water penetrating.
- Make sure to inspect local defects (e.g. scratches) which could result in a premature deterioration of the coating or corrosion of the substrate.

Once the building has been completed, particular attention should be paid to holders/supports, coating defects, boreholes, deformations caused by rivets, as well as to the general basic cleaning.

## Cleaning

Annual cleaning is recommended. The surfaces should be cleaned either manually using a soft brush or by means of a high-pressure cleaner (max. 50 bar) with clean water. If necessary, a mild cleaning agent (pH 6-7) may be added, up to max. 10%. For details please contact your supplier (GRM - Gütegemeinschaft für die Reinigung von Metallfassaden e.V.). Cleaning should take place from top to bottom. After cleaning, rinse with clean water to remove any cleaning agent residue.

Generally, we recommend trying out the cleaning agent on an unobtrusive part of the object to be cleaned to check whether the surface appearance is affected.

**Do not clean surfaces heated by the sun (>40°C) as the quick drying process may cause blemishes.**

## Cleaning agents

A list of neutral cleaning agents for organically coated aluminium components can be obtained from

Gesamtverband der Aluminiumindustrie e. V.  
Phone +49 211 47 96 -0  
Fax +49 211 47 96 -408  
[www.aluinfo.de](http://www.aluinfo.de)

Please observe the manufacturer's cleaning and safety instructions!

For further information, e.g. addresses of approved cleaning companies, please contact

Gütegemeinschaft für die Reinigung von Metallfassaden e.V. (GRM)

Phone +49 9 11 20 44 41  
Fax +49 9 11 22 67 55  
[www.grm-online.de](http://www.grm-online.de)

## Non-suitable cleaning agents

Please do not use any strong alkaline cleaning agents such as potassium hydroxide, sodium carbonate or caustic soda, any strong acidic products or highly abrasive cleaning agents such as Vim, Ajax or lmi, or any cleaning agents that corrode paint.

## Standard Data sheet

<b>Panel-Thickness:</b>		Standard	Unit	3 mm	4 mm	6 mm
Thickness of Aluminium Layers			[mm]		0.50	
Weight			[kg/m <sup>2</sup> ]	4.5	5.5	7.3
Width			[mm]	1000 / 1250 / 1500		
<b>Technical properties:</b>						
Section modulus	W	DIN 53293	[cm <sup>3</sup> /m]	1.25	1.75	2.75
Rigidity (Poisson's ratio $\mu = 0,3$ )	E-I	DIN 53293	[kNcm <sup>2</sup> /m]	1250	2400	5900
Alloy		EN 573-3		EN AW-5005A (AIMg1)		
Temper of Aluminium Layers		EN 515		H22/H42		
Modulus of Elasticity		EN 1999 1-1	[N/mm <sup>2</sup> ]	70'000		
Tensile Strength of Aluminium		EN 485-2	[N/mm <sup>2</sup> ]	$R_m \geq 130$		
0.2 % Proof Stress		EN 485-2	[N/mm <sup>2</sup> ]	$R_{p0.2} \geq 90$		
Elongation		EN 485-2	[%]	$A_{50} \geq 5$		
Linear Thermal Expansion		EN 1999 1-1		2.4 mm/m at 100°C temperature difference		
<b>Core:</b>						
Polyethylene, Type LDPE			[g/cm <sup>3</sup> ]	0.92		
<b>Surface :</b>						
Lacquering				Coil Coating Fluorocarbon based (e.g. PVdF)		
Gloss (initial value)		EN 13523-2	[%]	30 - 80		
Pencil Hardness		EN 13523-4		HB - F		
<b>Acoustical Properties:</b>						
Sound Absorption Factor	$\alpha_s$	ISO 354		0.05		
Sound Transmission Loss	$R_w$	ISO 717-1	[dB]	25	26	27
Loss Factor	d	EN ISO 6721		0.0072	0.0087	0.0138
<b>Thermal properties:</b>						
Thermal Resistance	R	DIN 52612	[m <sup>2</sup> K/W]	0.0069	0.0103	0.0172
Heat Transition Coefficient	U	DIN 4108	[W/m <sup>2</sup> K]	5.65	5.54	5.34
Temperature Resistance			[°C]	- 50 ... + 80		

# ALUCOBOND® plus

## Standard Data sheet

<b>Panel-Thickness:</b>		Standard	Unit	3 mm	4 mm
Thickness of Aluminium Layers			[mm]	0.50	
Weight			[kg/m <sup>2</sup> ]	5.9	7.6
Width			[mm]	1250 / 1500	
<b>Technical properties:</b>					
Section Modulu	W	DIN 53293	[cm <sup>3</sup> /m]	1.25	1.75
Rigidity (Poisson's ratio $\mu = 0,3$ )	E-I	DIN 53293	[kNcm <sup>2</sup> /m]	1250	2400
Alloy		EN 573-3		EN AW-5005A (AIMg1)	
Temper of Aluminium Layers		EN 515		H22/H42	
Modulus of Elasticity		EN 1999 1-1	[N/mm <sup>2</sup> ]	70'000	
Tensile Strength of Aluminium		EN 485-2	[N/mm <sup>2</sup> ]	$R_m \geq 130$	
0.2 % Proof Stress		EN 485-2	[N/mm <sup>2</sup> ]	$R_{p0.2} \geq 90$	
Elongation		EN 485-2	[%]	$A_{50} \geq 5$	
Linear Thermal Expansion		EN 1999 1-1		2.4 mm/m at 100°C temperature difference	
<b>Core:</b>					
Mineral filled polymer					
<b>Surface:</b>					
Lacquering					
Coil Coating Fluorocarbon based (e.g. PVdF)					
Gloss (initial value)		EN 13523-2	[%]	30 - 80	
Pencil Hardness		EN 13523-4		HB - F	
<b>Acoustical Properties:</b>					
Sound Absorption Factor	$\alpha_s$	ISO 354		0.05	
Sound Transmission Loss	$R_w$	ASTM E90	[dB]	STC: 30	OITC: 24
<b>Thermal properties:</b>					
Thermal Resistance	R	ASTM C518	[m <sup>2</sup> K/W]	0.007	0.009
Temperature Resistance			[°C]	-50 ... +80	

# ALUCOBOND® A2

## Standard Data sheet

<b>Panel-Thickness:</b>		Standard	Unit	<b>3 mm</b>	<b>4 mm</b>
Thickness of Aluminium Layers			[mm]	0.50	
Weight			[kg/m <sup>2</sup> ]	5.9	7.6
Width			[mm]	1250 / 1500	
<b>Technical properties:</b>					
Section modulus	W	DIN 53293	[cm <sup>3</sup> /m]	1.25	1.75
Rigidity	E-I	DIN 53293	[kNcm <sup>2</sup> /m]	1250	2400
Alloy		EN 573-3		EN AW-5005A (AlMg1)	
Temper of Aluminium Layers		EN 515		H22/H42	
Modulus of Elasticity		EN 1999 1-1	[N/mm <sup>2</sup> ]	70'000	
Tensile Strength of Aluminium		EN 485-2	[N/mm <sup>2</sup> ]	R <sub>m</sub> ≥ 130	
0.2% Proof Stress		EN 485-2	[N/mm <sup>2</sup> ]	R <sub>p0.2</sub> ≥ 90	
Elongation		EN 485-2	[%]	A <sub>50</sub> ≥ 5	
Linear Thermal Expansion		EN 1999 1-1		2.4 mm/m at 100°C temperature difference	
<b>Core:</b>					
Mineral compound, polymer bonded					
<b>Surface:</b>					
Lacquering					
Coil Coating Fluorocarbon based (e.g. PVdF)					
Gloss (initial value)		EN 13523-2	[%]	30 - 80	
Pencil Hardness		EN 13523-4		HB - F	
<b>Acoustical Properties:</b>					
Sound Absorption Factor	α <sub>s</sub>	ISO 354		0.05	
Sound Transmission Loss	R <sub>w</sub>	ISO 717-1	[dB]	27	27
Loss Factor	d	EN ISO 6721		0.004	0.005
<b>Thermal properties:</b>					
Thermal Resistance	R	DIN 52612	[m <sup>2</sup> K/W]	0.002	0.003
Thermal conductivity	λ	DIN 52612	[W/mK]	1.5	1.33
Heat Transition Coefficient	U	DIN 4108	[W/m <sup>2</sup> K]	5.81	5.78
Temperature Resistance			[°C]	-50 ... +80	

## Informations

(Please request)

ALUCOBOND®	Information folder
ALUCOBOND®	CD-ROM (Examples for fascia claddings)
ALUCOBOND®	CD-ROM with addresses of suppliers for: machines – tools – accessories – profiles/profile systems
ALUCOBOND®	Documentation file with examples for fascia claddings and texts for tendering incl. CD ROM

## Samples

Original samples with standard surfaces

# ALUCOBOND®

[www.alucobond.com](http://www.alucobond.com)



3A Composites GmbH  
D-78224 Singen, Germany  
Phone +49 (0) 7731 802347  
Fax +49 (0) 7731 802845  
[info.eu@alucobond.com](mailto:info.eu@alucobond.com)